



VEGA

P A C K 1 2 0



RACCOGLITORE SEMI-AUTOMATICO
SEMI-AUTOMATIC COLLECTOR

Caratteristiche tecniche / <i>Technical Data</i>		PACK 120
Fustellato chiuso / <i>Folded blank</i>	max mm min mm	1200 200
Altezza / <i>Blank length</i>	max mm min mm	1400 200
Altezza pacco / <i>Stack height</i>	max mm	300
Materiale lavorato / <i>Convertible material</i>	  g/m ² 500 ± 1500 N-F-E-B-C-A K-EB-BC-BA	
Velocità / <i>Speed</i>	m/min	max 100
Motore a velocità variabile / <i>Variable speed motor</i>	kW	6
Aria compressa / <i>Compressed air</i>	bar	6
Peso netto / <i>Net weight</i>	kN	28

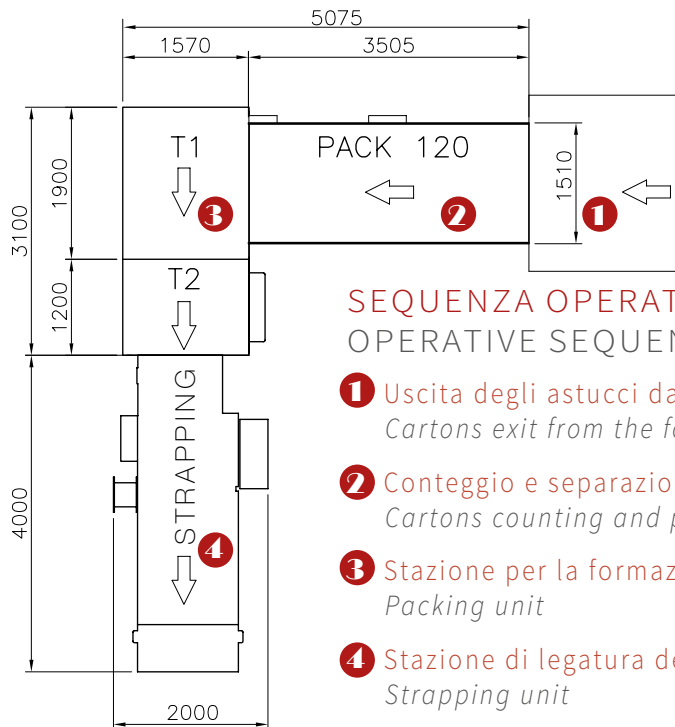
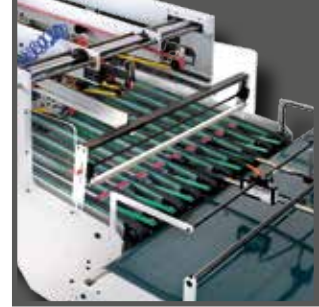

SEQUENZA OPERATIVA OPERATIVE SEQUENCE

- 1 Uscita degli astucci dalla piega incollatrice
Cartons exit from the folder gluer
- 2 Conteggio e separazione degli astucci
Cartons counting and parting
- 3 Stazione per la formazione del pacco
Packing unit
- 4 Stazione di legatura del pacco
Strapping unit

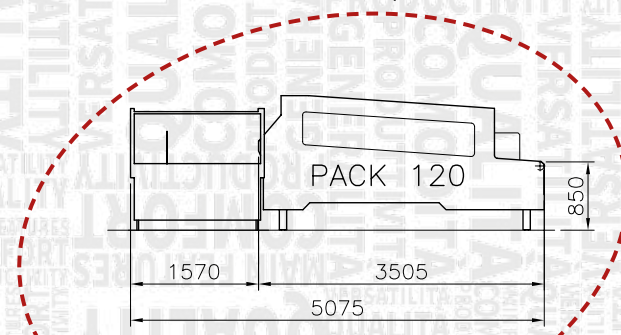
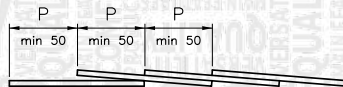
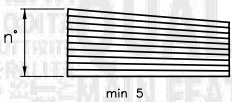
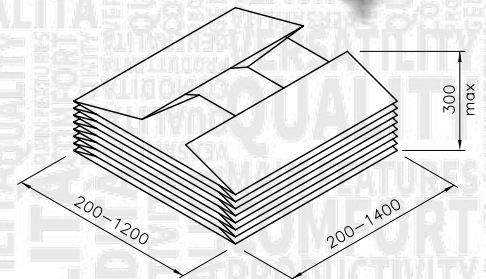
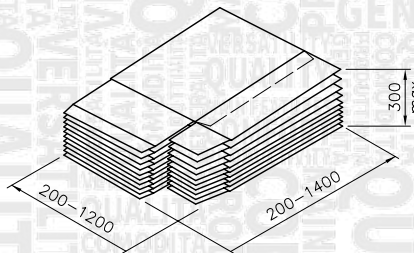
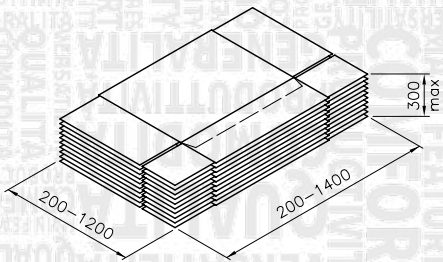

P A C K 1 2 0

Il fine linea Vega Pack 120 conta e separa i fustellati in uscita da qualunque piega incollatrice. Il pacco generato può essere raccolto a mano per la legatura oppure inviato automaticamente ad una stazione ad angolo T1/T2 che predispone il pacco in modo opportuno da poterlo squadrare sui 4 lati e legarlo con uno o due nastri per mezzo di una reggiatrice automatica. La stazione T2 è predisposta per il ribaltamento manuale del pacco al fine di consentire una migliore pallettizzazione dei pacchi.

The Vega Pack 120 counts and separates the boxes after any folder gluer. The parcel can be manually collected for manual strapping or it can be automatically sent to a corner station T1/T2 which prepares the parcel in the correct way in order to be squared on the four sides and strapping it with one or two straps by using an automatic strapping machine. The T2 Station is fit for the manual overturning of the parcel in order to obtain a better parcel palletizing.



MACCHINE PER CARTOTECNICA
SOLID AND CORRUGATED BOARD MACHINES



VEGA S.R.L .
VIALE DELL'INDUSTRIA, 6 • 20037 PADERNO DUGNANO • MILANO • ITALY
TEL. +39 02 99046212 • FAX +39 02 99046202
COMM@VEGAGROUP.IT • WWW.VEGAGROUP.IT